

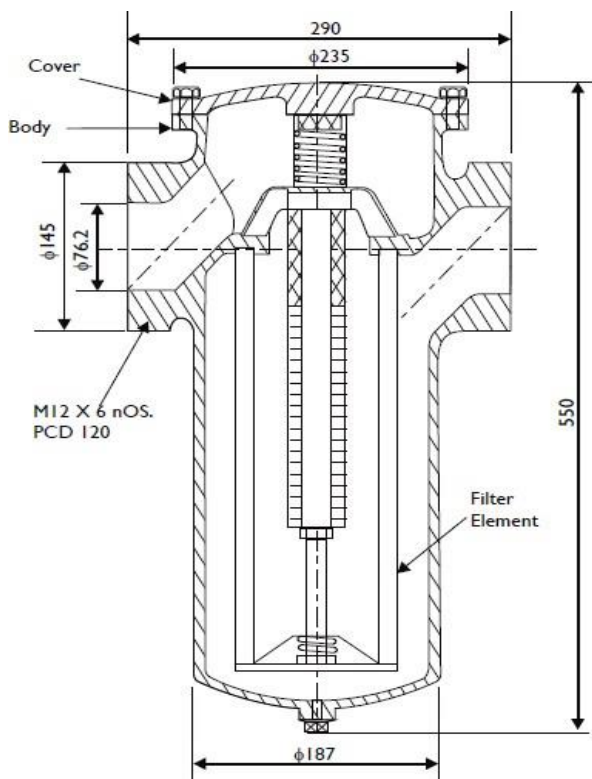

## ILF 600

- The Hydax In-line Filter model ILF is an all-cast construction and is made from superior grade castings.
- The maximum flow capacity is 600 LPM with fluid viscosity of 80 SSU at 40° C.
- These filters are rated for working pressures upto 20 kg/cm and the filtration is of 25 or 10 microns.
- The port connections range from 2”BSP to 3”BSP SAE flange.
- Strong ferrite magnets are provided inside the cartridge flow path to arrest ferrous particles. Adequate internal area is provided to minimize pressure drop.



Pressure Drop Curve with Clean Element

